



# LYNX POWER 3

---

## SPECIFICATIONS

- The Lynx Power 3 (LP3) maintains efficient AC Emergency Power to operate all elevators, providing superior dependability and security to commercial/industrial environments in a small footprint.

## POWER RATING

- 5 kVA - 80 kVA output uses the latest DSP/PWM technology to provide the most advanced performance and reliability features.

## PROTECTION

- Provides overload, surge and undercurrent protection using DSP/PWM technology and DSPM Watchdog Software to protect system performance and reliability.
- Surge protection against load surges as defined in ANSI/IEEE C62.45 category A and B.

## INPUT

- 208, 240, 480 VAC input 60Hz

## OUTPUT

- 208, 240, 480 is  $\geq 92\%$  efficient at 100% linear load

## BATTERIES

- 10 Minutes Standard (Consult Factory for 90 minutes or greater).
- Sealed, maintenance-free, lead calcium (AGM) batteries.
- 10-Year prorated warranty.
- DSP/PWM Smart Battery Monitoring System is TEMPERATURE COMPENSATED maintaining maximum runtime and battery life.
- Microprocessor controlled recharge and DSP/PWM overcharge protection standard.

## CODES

- UL 924, UL 1778, meets NFPA 101, NFPA 70, NEC and OSHA standards
- Cities of Chicago, Los Angeles and New York approved
- Complies with the Buy American Act

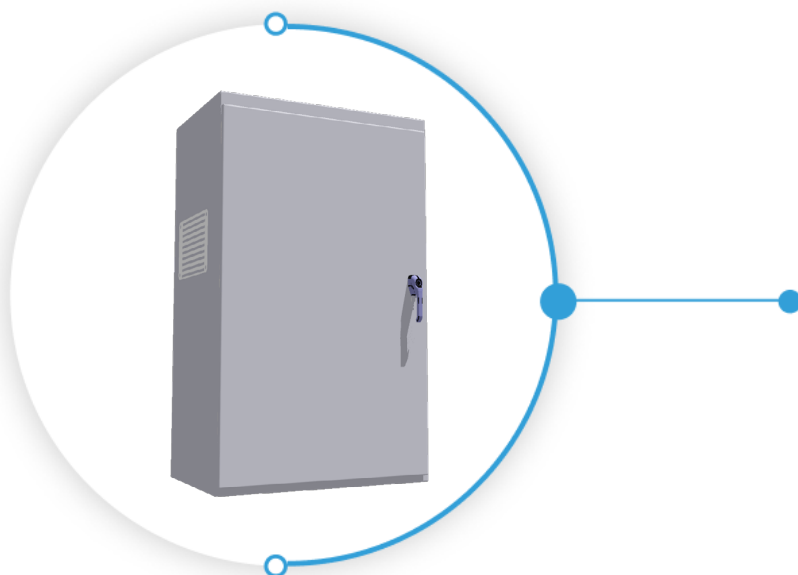

5 kVA - 80 kVA

Three Phase

Uninterrupted

Emergency

Lighting and

Power

Systems

## REGEN POWER

- Lynx Power is designed to convert regenerated power from the elevator to recharge the battery during a power outage. Lynx Power operates in stand-by mode when utility power is available allowing the regenerative elevated power to be absorbed into the building emulating normal utility operating conditions.

## DIAGNOSTICS AND MAINTENANCE

- DSP/PWM technology and DSPM Watchdog Software provides complete self diagnostic capabilities and LED Monitoring.
- Informative advanced Display and Alarms keep you in control of your emergency lighting environment 24/7.
- Automatically performs periodic self-tests ensuring a safely lighted environment prior to an emergency.
- Single point of testing instead of multiple testing points with battery packs.

## NEMA3 CABINET

- Modular design enables flexible installation
- Forced air cooling for maximum reliability
- Systems up to 12 KW are self contained; larger systems require external battery cabinet(s)

## INSTALLATION

- Modular design and small footprint allow easy installation in electrical closet or other convenient locations
- Phone assisted factory start-up standard for all systems
- Extended warranty available

## SPECIAL APPLICATIONS

- DSPM offers numerous optional devices to meet unusual or difficult application parameters.
- ECM - Environmental Circuit Module allows fixtures and lamps on the emergency circuit(s) to be operated by normal switching and/or dimming devices in NON-emergency conditions.

## WARRANTY

- 1-Year full warranty on system electronics
- System 1-year on-site warranty labor with DSPM phone assisted start-up
- 5-Year powertrain warranty
- Maintenance contracts available
- Battery warranty 1-year with 9-years pro-rated

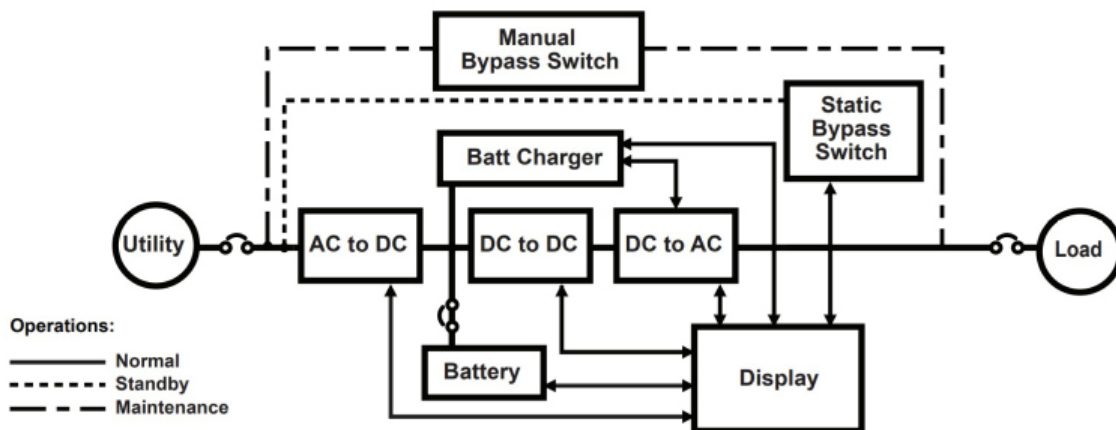

Lynx Power 3	Power Rating	UPS Cabinet (@ 10min Runtime)			Battery Cabinet (@ 10min Runtime)				Combined Weight	British Thermal Unit	Battery Type	Voltage(VAC)	Input/Output Protection	Safety Approvals
	kVA/kW	W	H	D	No.	W	H	D	(lbs)	BTU		Input / Output		
LP3	3	42"	71"	32"	N/A				TBD		Sealed Lead Acid (SLA)	208VAC or 408VAC (Consult Factory for Others)	Circuit Breaker Standard	UL924 UL1778 NFPA101 NFPA70 (NEC)
	3.4	42"	71"	32"										
	3.8	42"	71"	32"										
	4	42"	71"	32"										
	4.2	42"	71"	32"										
	4.5	42"	71"	32"										
	4.7	42"	71"	32"										
	5.25	42"	71"	32"										
	6	42"	71"	32"										
	7	42"	71"	32"										
	8	42"	71"	32"										
	10	42"	71"	32"										
	12	42"	71"	32"										
	12.5	42"	71"	32"										
	14	42"	71"	32"										
	16	50"	71"	32"										
	18	50"	71"	32"										
	20	50"	71"	32"										
	21	50"	71"	32"										
	24	42"	71"	32"										
30	42"	71"	32"											
40	50"	71"	32"											
50	50"	71"	32"											
60	50"	71"	32"											
80	50"	71"	32"											
					Consult Factory									

The Lynx Power 3 provides the simplicity and reliability that is critical when providing an alternative source of power to any environment. Easy installation ..."simplicity"...connect the LP3 to the emergency circuit(s) and everything is backed up..."reliability"...during a power outage. LP3 will simply continue to operate at "full elevation operation." DSPM Watchdog® software keeps your environment safe while self-diagnostics help maintain equipment to a high standard. Superior surge suppression assures the highest quality of power being delivered to all loads all time. Equipment, elevator, and lamp life are maximized.

We sincerely hope you never experience a real emergency, but if you do, you deserve the security, safety and peace of mind that the Lynx Power 3 DSPM ensures.

## ORDERING INFORMATION

Choose the bold face catalog nomenclature that best suites your needs.

Write them on the appropriate line. Order accessories as separate catalog number.

Example:

**LP3 - 15 - 208 - 208 10** (minutes of KVA backup. Consult Factory for 90 minutes or greater)

Description of example:

(15KVA, 208 Voltage In, 208 Voltage Out, 10 minutes)

LP3	15	208 - 208	OPTIONS	10
FAMILY	POWER RATING	VOLTAGE <sup>1</sup>		TIME <sup>3</sup>
Lynx Power	KVA	Input - Output		Minutes
	5	240 - 240	OCB - Output circuit breakers / voltage / quantity/amps/pole	5
	10	208 - 208	EPO - Emergency power off	10 (Standard)
	15	480 - 480	RSSP - Remote Indicator Panel	15
	20		SNMP - SNMP Card	20
	30		FC - Form C Contacts	25
	50		SRB - Seismic rated bracket	30
	80		STU3 - Onsite start-up	45
	100		*EMB - External maintenance bypass switch	60
	120		EW - Extended warranty	90
	150			120
				180
				240
				300

## NOTES:

1-Consult factory for other voltage requirements. Special voltages may effect the weight, size and number of cabinets.

2-One ECM is used per switching device or circuit.

3-Consult factory for other run times.

\*EMB cannot be used with OCB.

Specifications subject to change without notice.



439 S. Stoddard Avenue San Bernardino, CA 92401

Ph: 1.877.DSPM POWER 1.877.377.6769 Fax: 909.930.3335