



SPECIFICATIONS

The Isolation Transformer 3 maintains efficient power to operate even with the worst of power problems, providing superior dependability and reliability commercial/industrial environments in a small footprint.

POWER RATING

- 15 kVA - 500 kVA three phase output unit uses the latest DSP/PWM technology to provide the most advanced performance and reliability features

INPUT

- 208 or 480 VAC input 50-60Hz

OUTPUT

- 208Y/120 or 480Y/277VAC
- <200 nanoseconds response time

CODES

- Meets NFPA 101, NFPA 70, NEC and OSHA standards

PROTECTION

- Provides overload, surge and undercurrent protection
- Surge protection against load surges as defined in ANSI/IEEE C62.45 category A and B

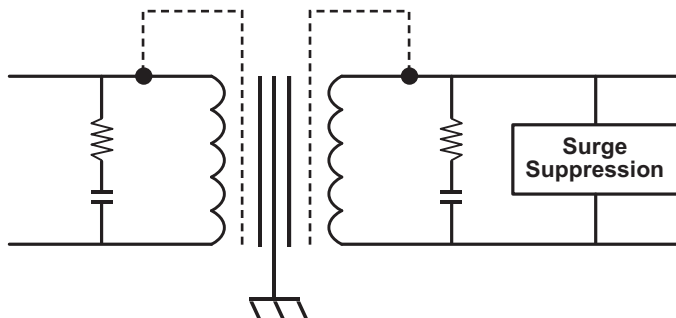

Catalog Number	
Project	Notes
Signature	Date

15 kVA - 500 kVA

Three Phase

Outdoor Isolation Transformer



DIAGNOSTICS AND MAINTENANCE

- DSP/PWM technology and DSPM *Watchdog Software* provides complete self diagnostic capabilities and LED Monitoring
- Informative advanced Display and Alarms keep you in control of your emergency lighting environment 24/7

NEMA 3R CABINET

- Modular design enables flexible installation
- Forced air cooling for maximum reliability
- All systems are self contained

INSTALLATION

- Modular design and small footprint allow easy installation in electrical closet or other convenient locations
- Phone assisted factory start-up standard for all systems
- Extended warranty available

SPECIAL APPLICATIONS

- DSPM offers numerous UL924 optional devices to meet unusual or difficult application parameters
- ECM - Environmental Circuit Module allows fixtures and lamps on the emergency circuit(s) to be operated by normal switching and/or dimming devices in NON-emergency conditions
- Dimming Panel Interface allows use with emergency lights controlled by common dimmer panel

WARRANTY

- 1-Year full warranty on system electronics
- System 1-year on-site warranty labor with DSPM phone assisted start-up
- 5-Year powertrain warranty
- Maintenance contracts available

ISOLATION TRANSFORMER



Isolation Transformer Series	Power Rating	Cabinet Dimensions			Weight (lbs)	BTU	Voltage (VAC)		Efficiency	Standard Features
		W	H	D			Input	Output		
ISOT3 (Consult factory for others)	kVA								96% at full loads; 98% at light loads	Common-Mode Noise Attenuation -120 dB Normal-Mode Noise Attenuation -20 dB/decade
	15	41"	48"	32"	510	2040	208 or 480	208Y/120 or 408/277		
	30	41"	48"	32"	630	4080				
	50	41"	48"	32"	740	6800				
	75	41"	48"	32"	880	10200				
	100	41"	48"	32"	1010	13600				
	125	41"	48"	32"	1100	17000				
	150	41"	48"	32"	1180	20400				
	175	41"	48"	32"	1360	23800				
	200	41"	48"	32"	1510	27200				
	225	41"	48"	32"	1610	30600				
	250	41"	72"	32"	1810	34000				
300	41"	72"	32"	2010	40800					
400	41"	72"	32"	2660	54400					
500	41"	72"	32"	2860	68000					

The Isolation Transformer 3 protects against switching power supplies, electrical noise, dirty power, transverse voltage and voltage disturbances. The ISO3 helps protect your computers and other sensitive equipment from the worst of any electrical problem. Along with protecting your printers, data transfers and sensitive circuit components. The ISO3 has 3 - 5% low impedance that minimizes the distortions, and 2 Faraday shield.

You deserve the **peace of mind** that the Isolations Transformer from **DSPM** ensures.

ORDERING INFORMATION

Choose the bold face catalog nomenclature that best suites your needs.

Write them on the appropriate line. Order accessories as separate catalog number.

Example:

ISOT3 - 50 - 208 208Y/120- HIT EW

Description of example:

(50 kVA, 208 Voltage In, 208Y/120 Voltage Out, High Isolation Transformer, Extended Warranty)

ISOT3			
FAMILY	POWER RATING	VOLTAGE ¹	OPTIONS
	kVA	Input - Output	SSS - Secondary Surge Suppression
	15	208 - 208Y/120	IF - Input Filter
	30	208 - 480Y/277	IOF - Input/Output Filter
	50	480 - 208Y/120	CMNA140 - Common Mode Noise Attenuation -140dB
	75	480 - 480Y/277	CMNA152 - Common Mode Noise Attenuation -152dB
	100		HIT - High Isolation Transformer
	125		HCR - Harmonic Reduction
	150		STU3 - Onsite Startup
	175		HE - Heat Exchanger
	200		HTR - Heater
	225		EW - Extended Warranty
	250		
	300		
	400		
	500		

NOTES:

1-Consult factory for other voltage requirements. Special voltages may effect the weight, size and number of cabinets.

Specifications subject to change without notice.



1921 S. Quaker Ridge Place
Ontario, CA 91761
Ph: 1.877.DSPM POWER
1.877.377.6769
Fax: 909.930.3335